

版本 REV.	日期 DATE	变更内容 DESCRIPTION	制图 DRAWN
A/0	2022/11/21	新版本	

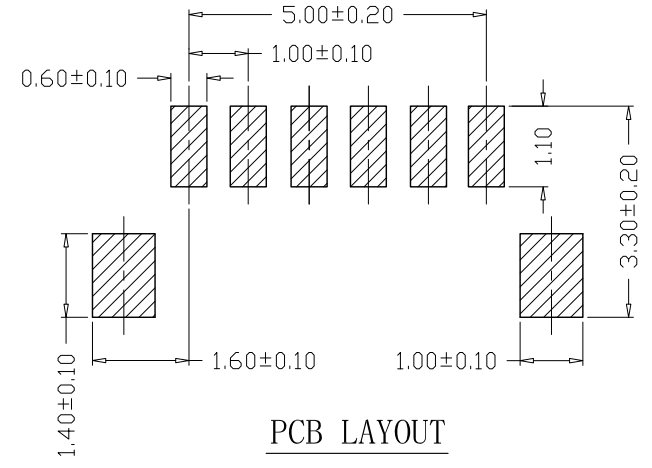

SPECIFICATIONS

- Current Rating: 1A AC, DC
- Voltage Rating: 125V AC, DC
- Temperatuer Range: -25°C~+85°C
- Contact Resistance: 20mΩ Max
- Insulation Resistance: 100MΩ Min
- Withstanding Voltang: 500V AC/minute
- Material:
Wafer LCP,UL94V-0
PIN Phosphor bronze Tin-plated
Fixing piece: Phosphor bronze Tin-plated

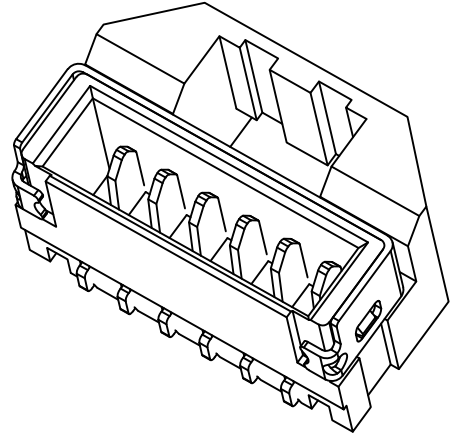
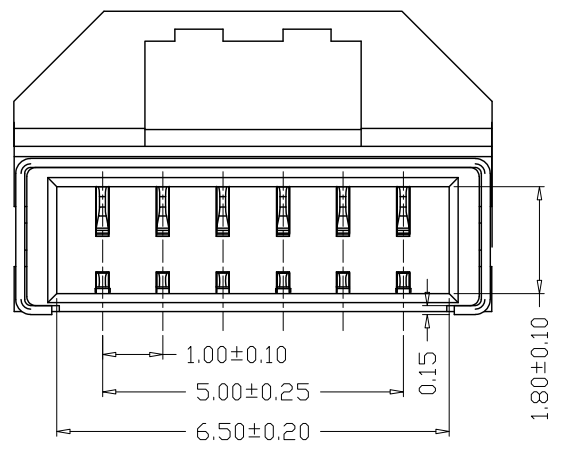
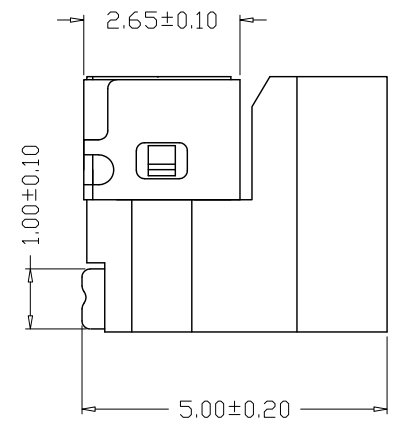
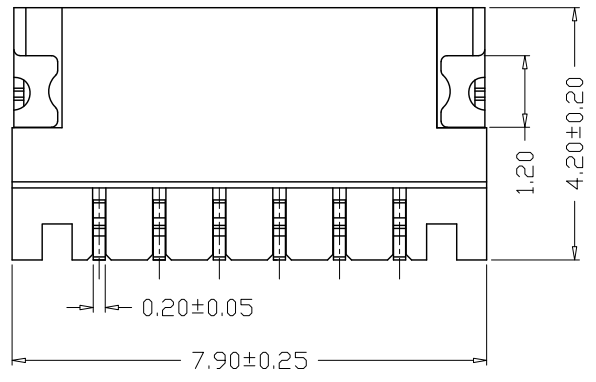

GENEERL TOLERANCE		制图	张迎春		料号	B10015-6AWB	版本	A
X.X±0.25	X.*±2'	DRAWING	2022、11、21		PART NO.	10C10-6A卧贴	页次	1/1
X.XX±0.20		审核	钱岳生		TITLE	WAFER SMT TYPE		
X.XXX±0.10		核准	张名		客户料号			
		APPROVAL	2022、11、22		CUTM. NO.			
		单位	MM	比例	1:1			
		UNITS	MM	SCALE	1:1			
					乐清市宏一电子有限公司			
					YUEQING HONGYI ELECTRONICS CO.,LTD			